



REAR DIFF SLIDER

WRANGLER | GLADIATOR | BRONCO

PLEASE READ ENTIRELY BEFORE YOU START

To guarantee a quality installation, we recommend reading these instructions thoroughly before beginning any work. These instructions assume a certain amount of mechanical ability and are not written nor intended for someone not familiar with auto repair.

| INCLUDED PARTS | QTY | REQUIRED TOOLS |
|---------------------|-----|-------------------|
| Differential Slider | 1 | Common Hand Tools |
| Differential Clamp | 1 | |
| U-Bolt | 2 | |
| Hardware Pack | 1 | |

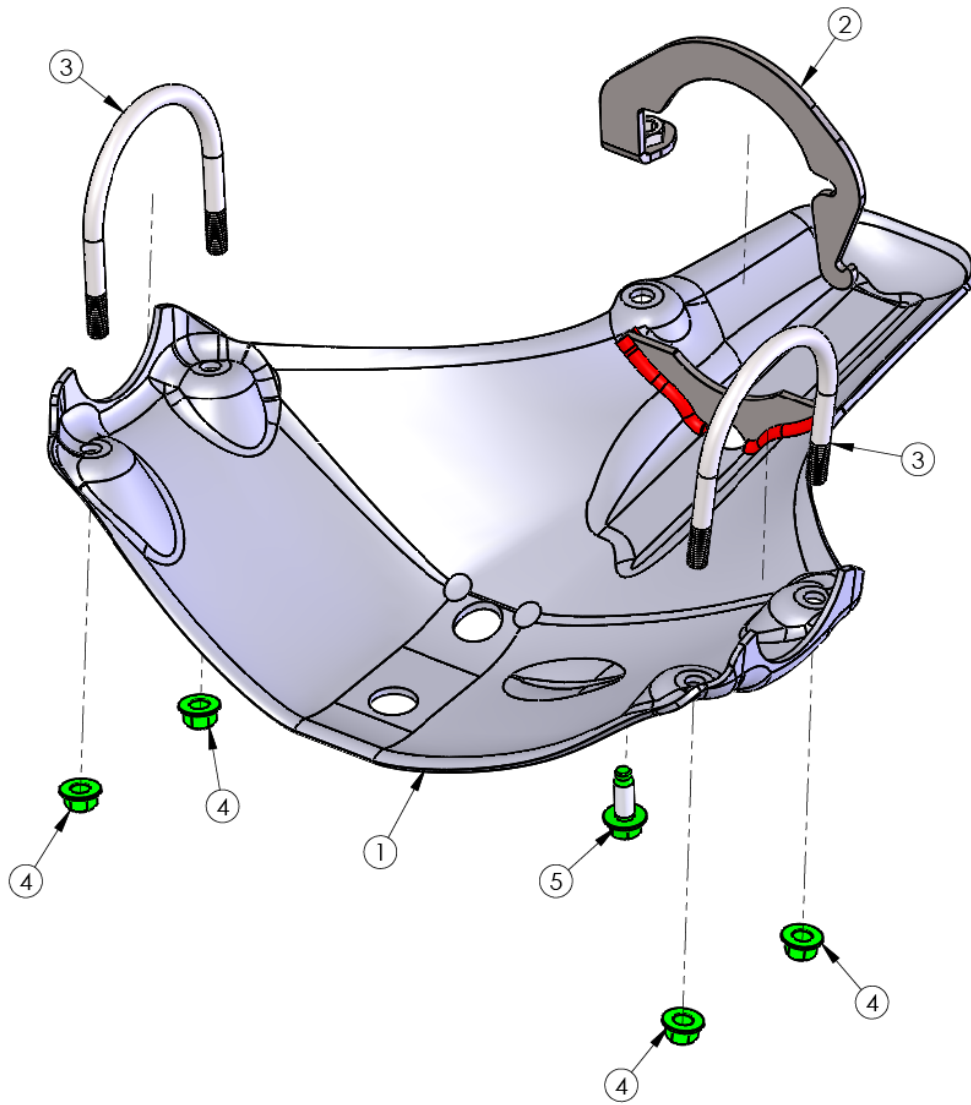

| ITEM NO. | PartNo | DESCRIPTION | QTY. |
|----------|------------|---|------|
| 1 | AJLZ0100AA | WELDMENT, JL SKID PLATE, REAR DIFF SLIDER | 1 |
| 2 | AJLZ0101AA | CLAMP, JL SKID PLATE, REAR DIFF SLIDER | 1 |
| 3 | AJLZ1953AA | U-BOLT, JL SKID PLATE, REAR DIFF SLIDER | 2 |
| 4 | 11546366 | M10 X 1.5 HEX FLANGE LOCK NUT | 4 |
| 5 | 11588738 | M10 X 1.5 X 25 HEX FLANGE BOLT | 1 |



1. Place the U-Bolts over the rear differential and through the differential slider. Loosely install the M10 nuts (fig. 1).

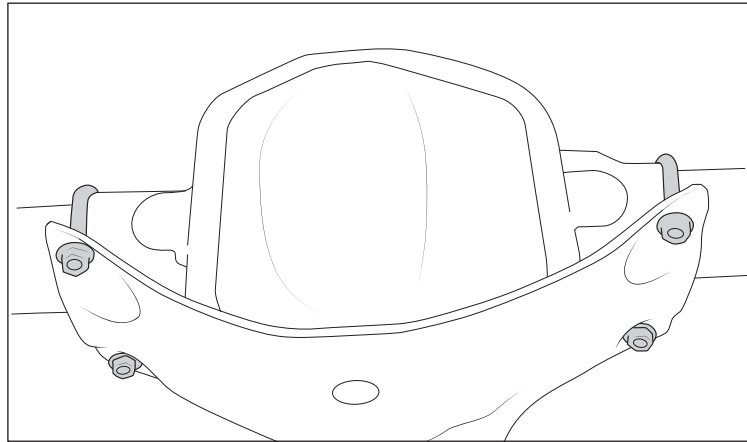

Figure 1

2. Insert the hooked end of the clamp into the slot. Pivot around the differential until aligned with the bolt hole. Install the M10 bolt and torque to 40 ft-lbs. (fig. 2).

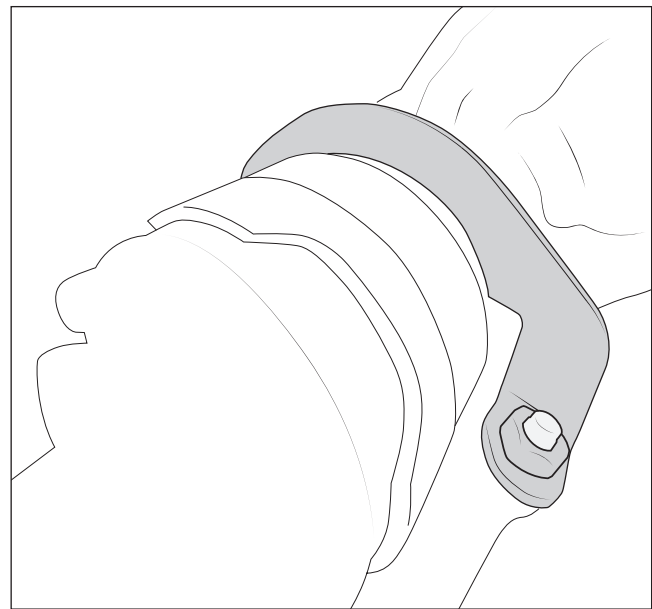
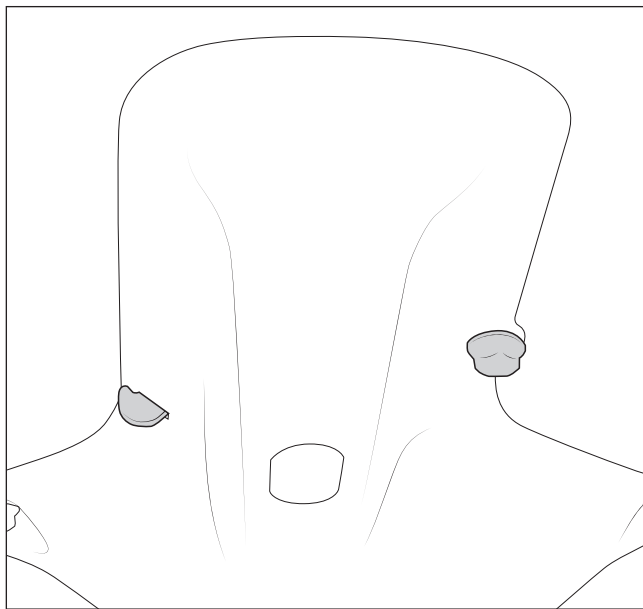

Figure 2

3. Tighten the nuts on the U-bolts to 40 ft-lbs.

NOTE: It is important that these are torqued down equally. Please make sure that the U-Bolts have close to the same amount of thread showing after being torqued down.